

YAMAHA

SPEAKER SYSTEM
SYSTEME D'ENCIENTES
LAUTSPRECHER SYSTEM

NS-10MC

Operation Manual
Mode d'emploi
Betriebsanleitung

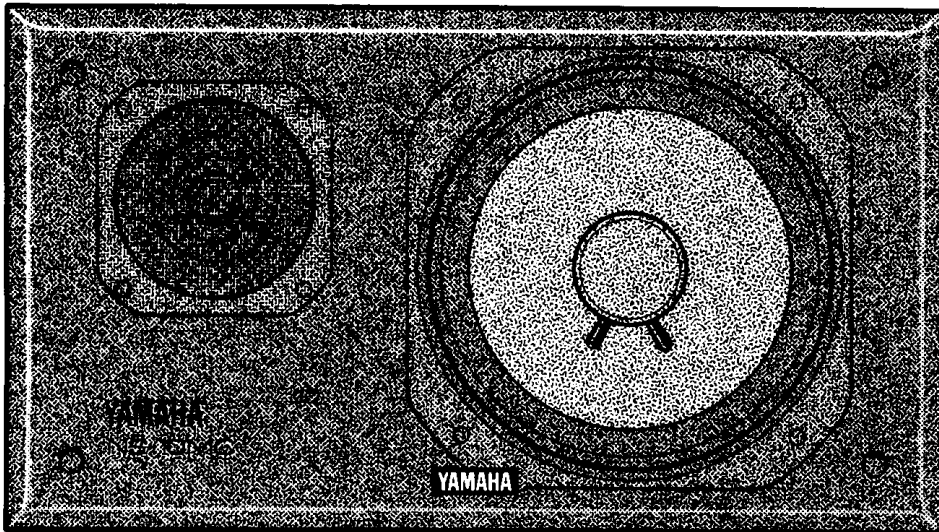

Congratulations on your purchase of a Yamaha NS-10MC Speaker System! The NS-10MC has been painstakingly designed to offer high performance and high reliability in demanding commercial applications. It is also an excellent choice for monitoring in home recording applications, or for simple audio listening enjoyment. In order to make the most of the outstanding sound the NS-10MC Speaker System has to offer, we urge you to read this Operation Manual thoroughly.

PRECAUTIONS

- Make sure that the power to your amplifier is turned OFF before connecting the speakers.
- Do not attempt to drive the speakers at levels above their rated power capacity. Excessive power can lead to serious damage.
- Be sure to match the polarity of the speaker terminals (+, -) with the outputs of your amplifier. If the polarity of the left and right speakers is reversed, proper stereo imaging will be impossible to achieve and irregular response will result.

FEATURES

- The NS-10MC can be mounted almost anywhere at any angle using the range of optional wall/ceiling mounting brackets and stand available from Yamaha.
- The NS-10M STUDIO—with an excellent reputation for studio recording applications—has been carefully designed to offer superb sound quality and durability.
- The attractive design of the real wood black finish and the speaker grille combine to provide a speaker that will be appropriate in any scene.

CONNECTION

BEFORE MAKING SPEAKER CONNECTIONS, MAKE SURE YOUR POWER AMPLIFIER IS TURNED OFF!

• Connecting the Speakers

The terminals on the rear of the left and right speakers must be connected to the corresponding speaker output terminals on the rear of your power amplifier with appropriate speaker cables. Make sure that the right speaker is connected to the speaker output terminals on the amplifier marked "R" or "RIGHT," and the left speaker is connected to the amplifier output terminals marked "L" or "LEFT." Also make sure that the red (+) terminal on each speaker is connected to the (+) output terminal of corresponding pair on the amplifier, and the black (-) terminal on the speaker is connected to the (-) terminal on the amplifier. If the speaker polarities are not properly matched, unstable stereo imaging and distortion will result.

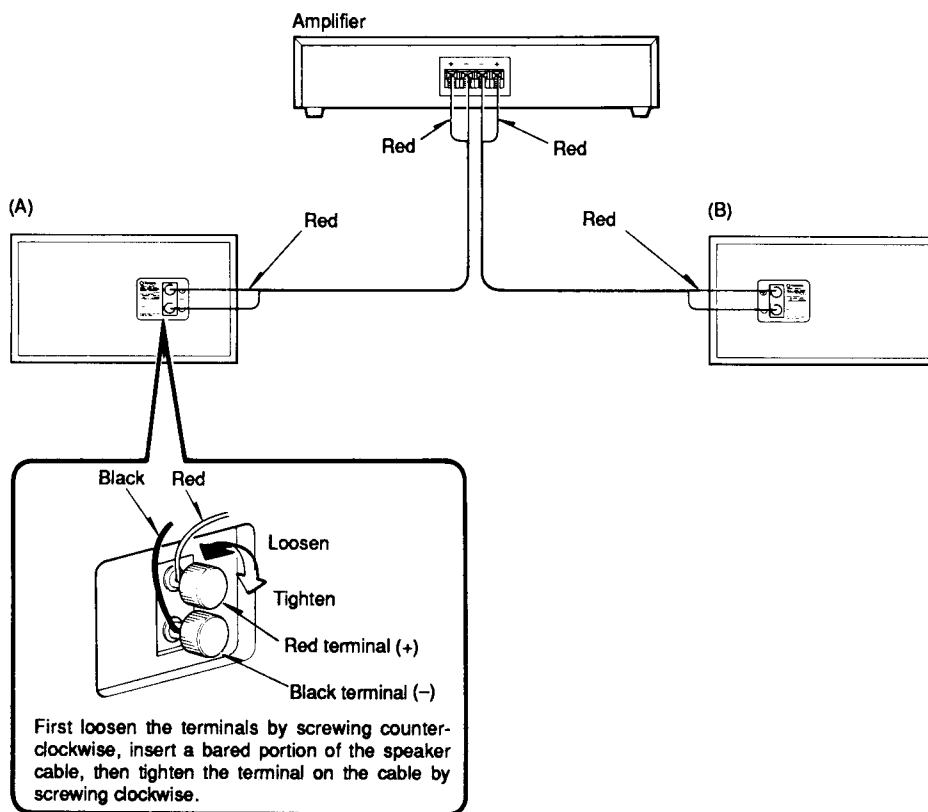

• Placement

The NS-10MC speakers are basically designed for horizontal placement, the speaker marked (A) in the above illustration corresponding to the right speaker and the (B) to the left. According to your requirements, however, the positions of the speakers may be reversed or they may be placed vertically with no effect on reproduction quality. The speakers are marked (A) or (B) to the right of the serial number on the rear-panel label.

• The Speaker Grille

The speaker grille can be removed if necessary (it can be simply pulled out and pushed back into place). When the NS-10MC is used on the STS50 stand, for example, the grill can be removed, turned upside-down and then replaced so that the name plate appears in the normal position.

SPECIFICATIONS

Frequency Range	60Hz~20kHz
Power Capacity	Program: 60W Max: 120W
Nominal Impedance	8 ohms
Sensitivity	90dB SPL (1W, 1m on axis)
Crossover Frequency	2kHz
Components	LF: JA1801 (18 cm cone) H: JA0518A (3.5 cm soft dome)
Enclosure	10.4 liter, acoustic-suspension bookshelf
Dimensions (W x H x D)	381.5 mm x 215 mm x 200.5 mm (15" x 8-1/2" x 7-7/8")
Weight	6.5 kg (14.3 lbs.) (1 speaker)

• Specifications and external appearance subject to change without notice.

TECHNICAL DATA

■ FREQUENCY RESPONSE/HARMONIC DISTORTION (1W, 1m on axis, in anechoic chamber)

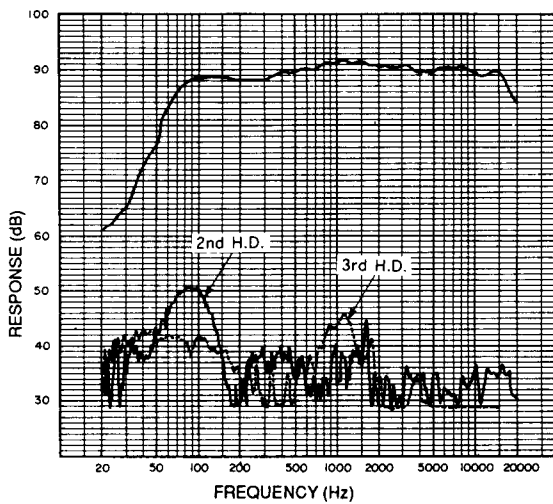

■ IMPEDANCE VS FREQUENCY

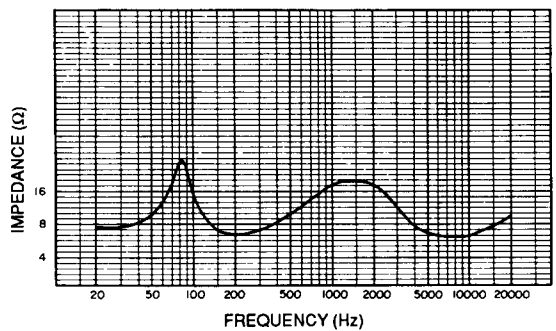

CIRCUIT DIAGRAM

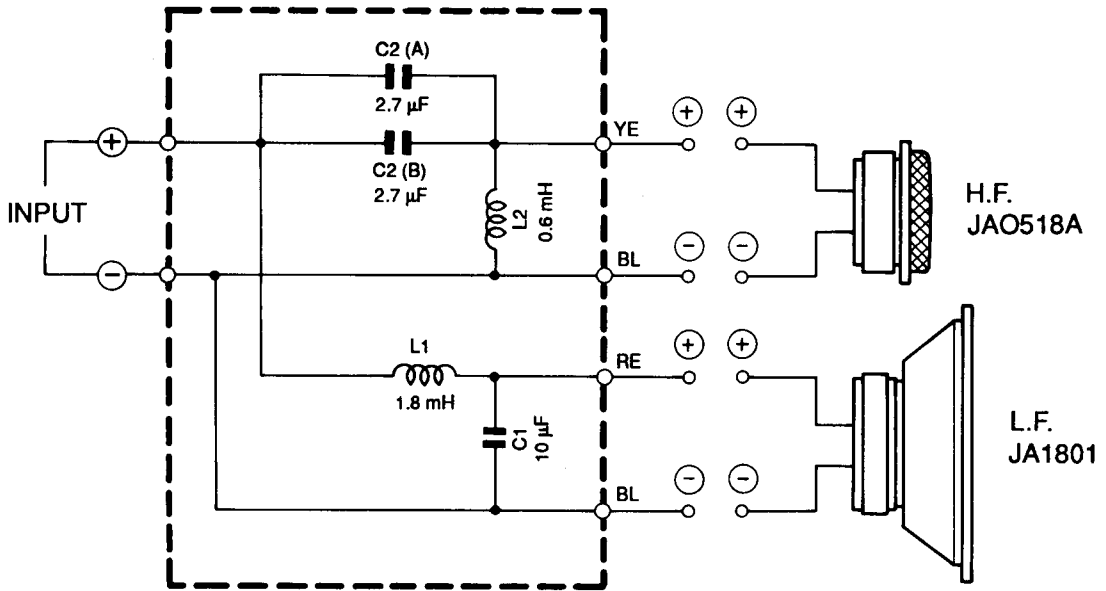

DIMENSION CHART

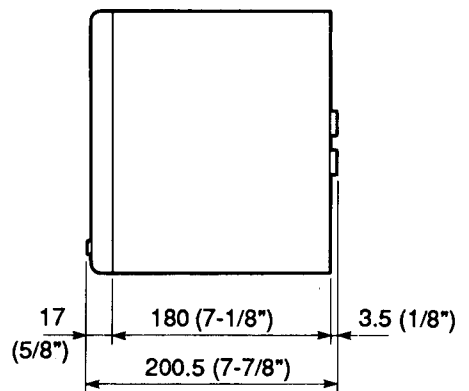
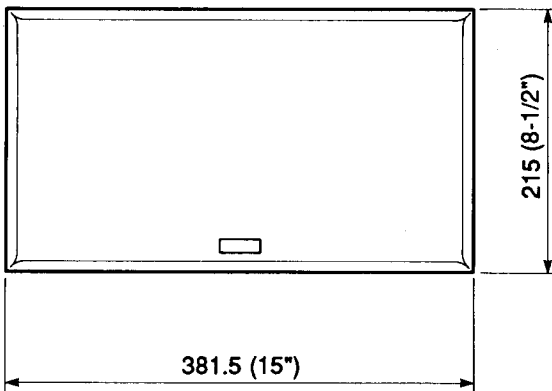
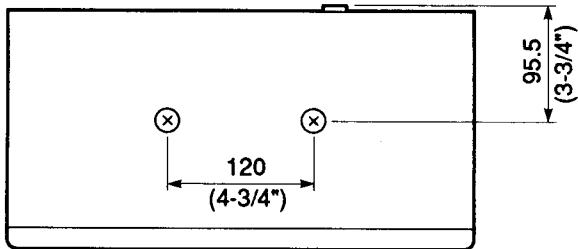

Unit: mm (Inch)

OPTIONS

■ BWS50-190/260/320 Ceiling Bracket

Ceiling-mount brackets are available in three lengths to suit a wide range of installation requirements. (BWS50-190: 190 mm. BWS50-260: 260 mm. BWS50-320: 320 mm)

• Ceiling Mount Example

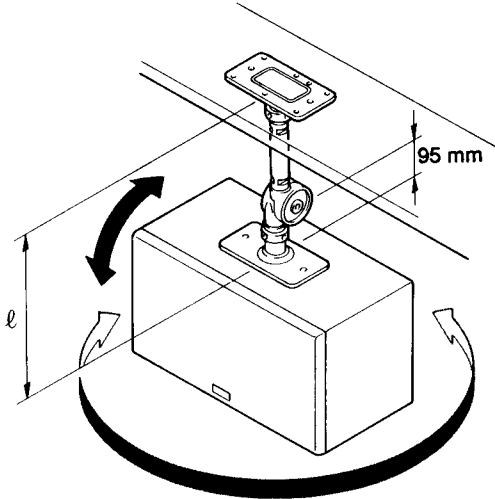

• Wall Mount Example

The BWS50-260 and BWS50-320 can also be used for wall mounting.

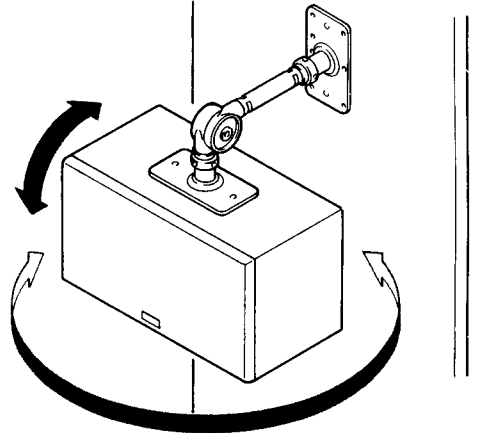

As shown in the illustrations above, the mounting brackets allow angle adjustment. The range of angle adjustment allowed by the BWS50-260 is smaller than that provided by the BWS50-320, so choose the bracket that provides the adjustment range that meets your installation requirements.

■ STS50 Speaker Stand

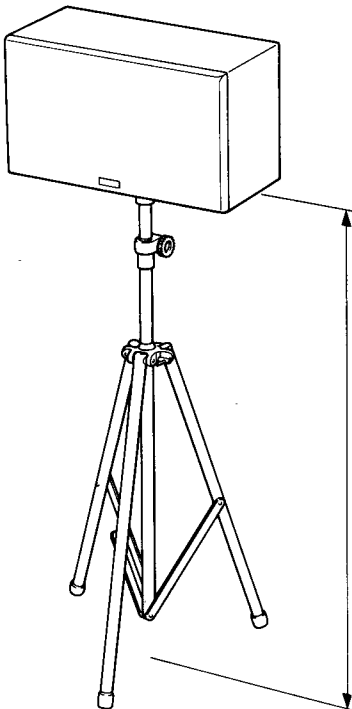

Stand height should be used from 1160 to 1820 mm.

YAMAHA

YAMAHA CORPORATION
10-1, Nakazawa-cho, Hamamatsu, Japan.